

The Family Handyman

W O O D W O R K S

Cedar-Strip **CANOE**

The beauty of wood and the strength of fiberglass come together in this build-it-yourself family canoe.

By **BRUCE KIEFFER**

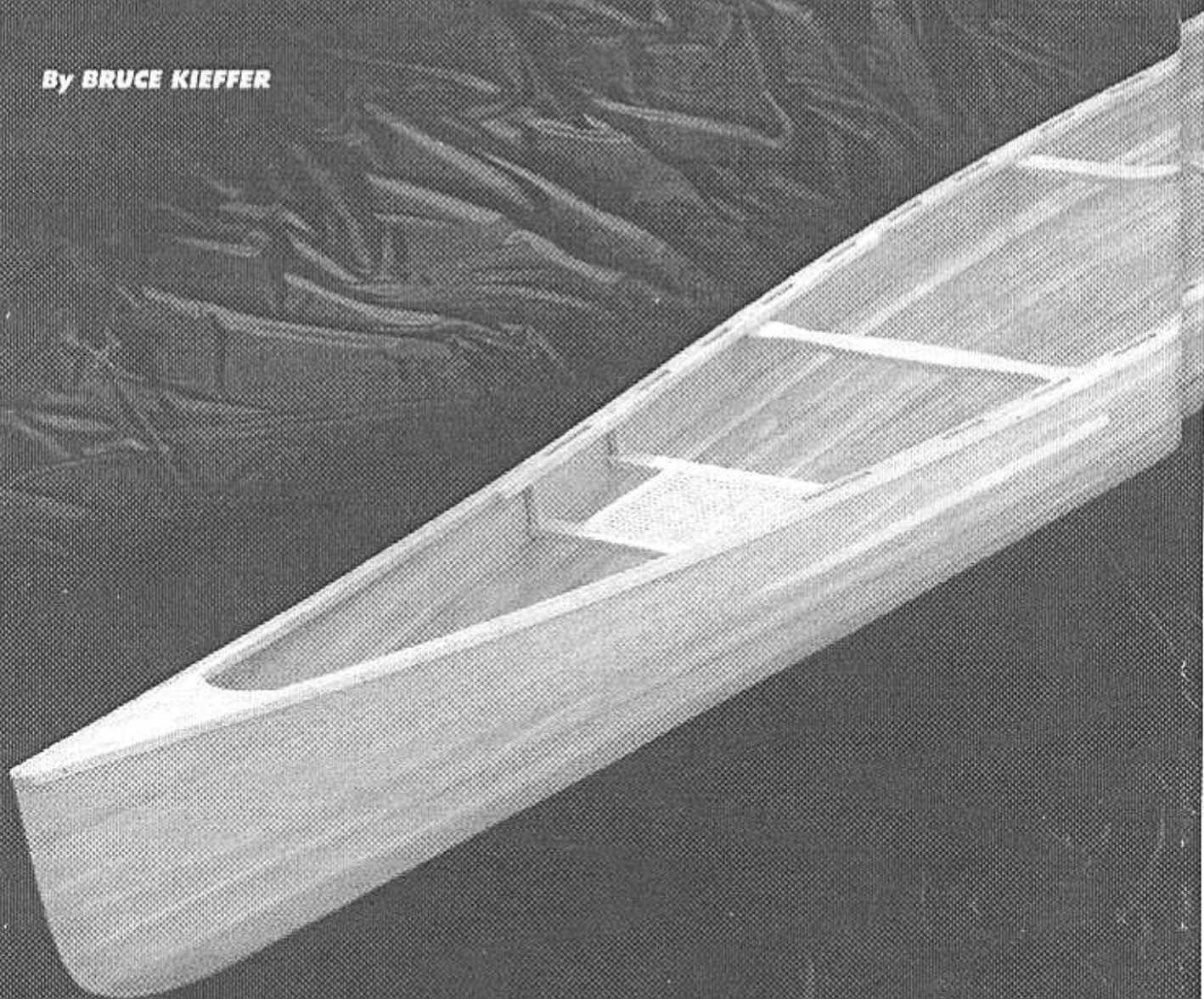

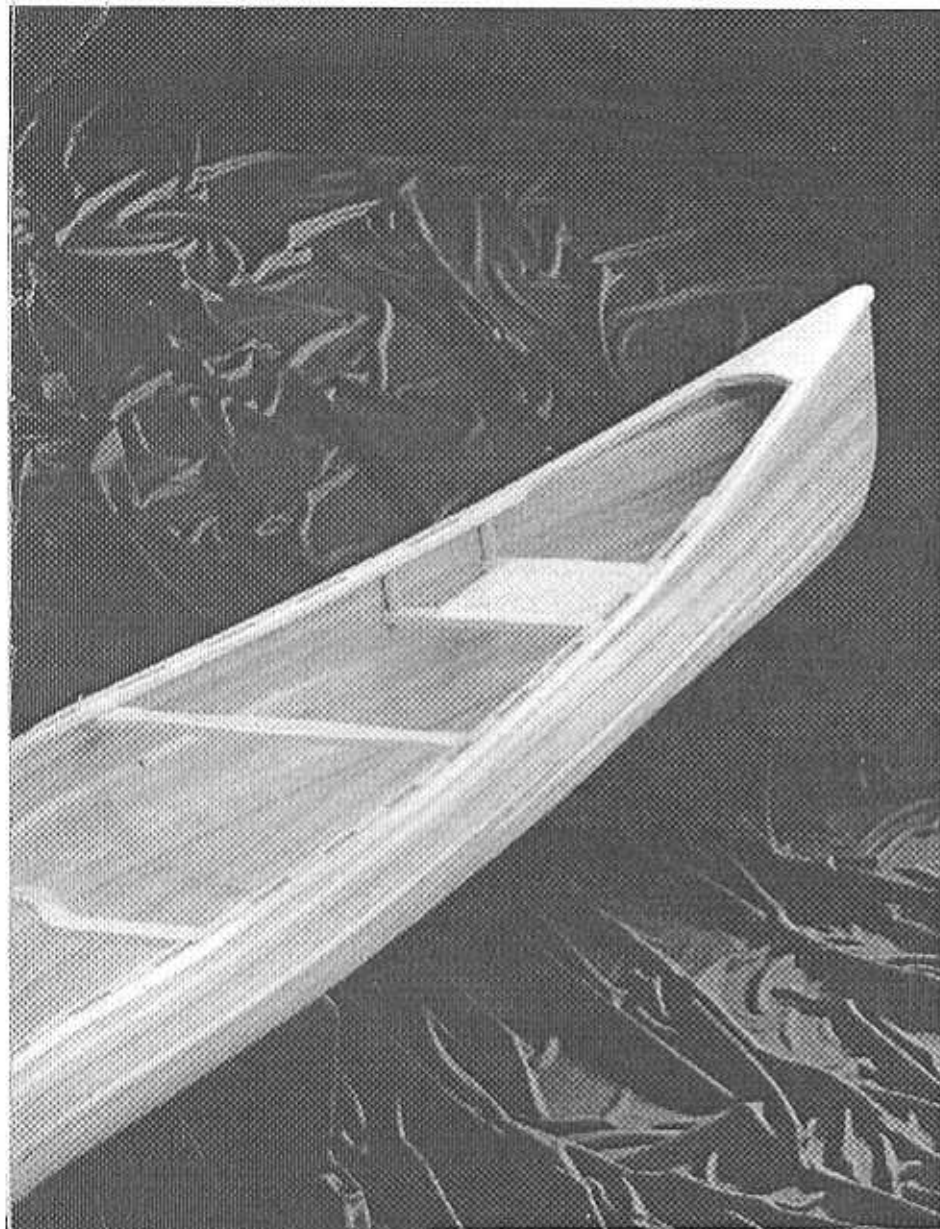

PART THREE:

*The home stretch —
fiberglassing the
inside and attaching
the trim.*

This month, in the last of our three-part series, we'll complete our cedar-strip canoe.

In our last two issues (May and June, '91), we constructed the form on which the canoe is built, then we stapled the cedar strips together to make the hull and put fiberglass on the outside of it. (If you need copies of Parts 1 and 2, see the Shopping List on p. 74.)

Now that the outside is covered with fiberglass, we can flip the canoe over, cover the interior with fiberglass, and build the seats, decks and other trim.

Fiberglassing the inside of the canoe is like doing the outside. However, instead of a single large sheet, which would be difficult to apply without wrinkles, the fiberglass is laid in sections. The interior fiberglass is also left a little rough so you're less likely to slip, and to reduce glare.

The trim is made from ash instead of cedar. The "gunwales" (the upper edges of the hull) are

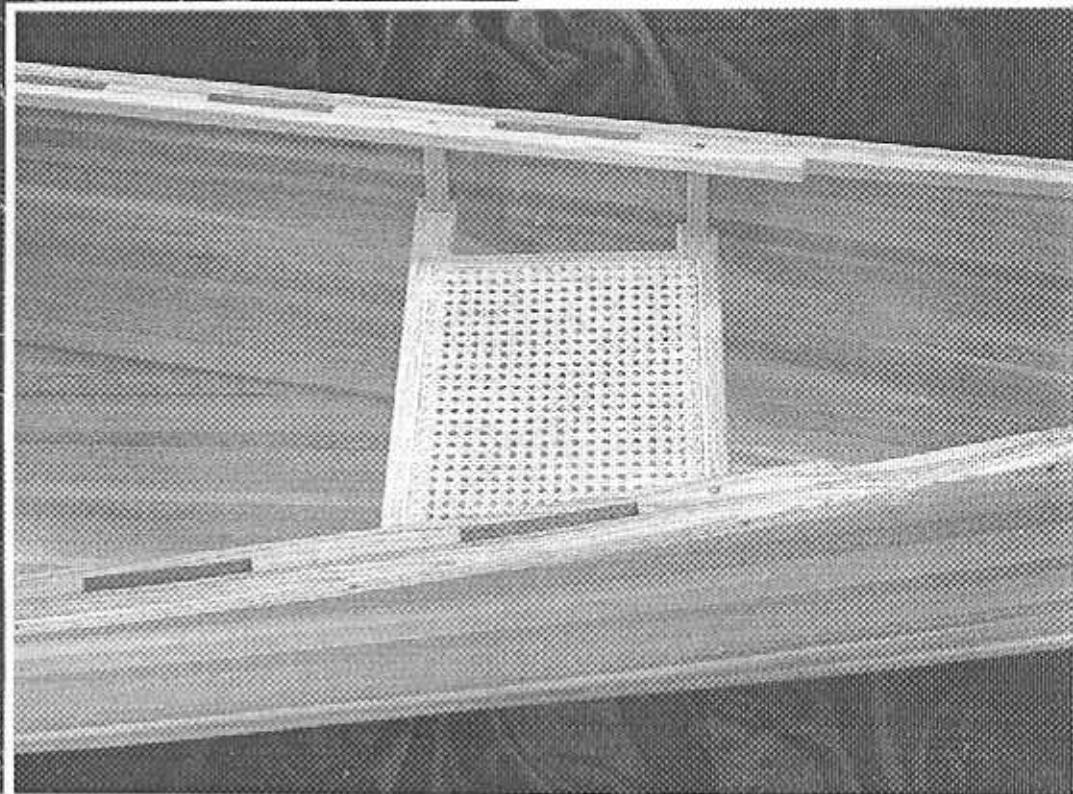

Cedar-Strip CANOE

the most important part of the trim — they protect the edge of the hull, they stiffen and strengthen the entire boat, and they provide a place to attach the seats and thwarts. The gunwales consist of a three-part sandwich: a strip of ash on the inside (the "inwale"), then the fiberglassed hull, then a strip of ash on the outside (the "outwale"). The inwale has openings in it so water can drain out when the canoe is upside down.

The seats are simply ash frames with prewoven cane in the middle, and the

decks and thwarts are simpler yet — just shaped pieces of ash. All are simply screwed or bolted on.

Here are the details.

MAKE THE SLING STANDS

Sling stands hold the canoe once it's off the strongback, so you can work on the interior. They're also good for holding the canoe in the winter. Cut pieces X-CC to the finished dimensions shown in the Cutting List, and assemble the sling stands as shown in Fig. A.

REMOVE THE HULL FROM THE STRONGBACK

Unbolt molds 2-6 and 8-12 from their mold supports. Use a rubber mallet to tap these molds free from the hull. Unbolt the remaining molds from their mold holders and remove the hull and molds from the strongback (Photo 1). Place the hull in the sling stands.

Tap the remaining molds free from the hull. If you have trouble removing the end molds, free them by hammering a stick against their top corners at



REMOVE THE CANOE from the strongback and place it on sling stands, which support it while you work on the inside of the hull and the trim.

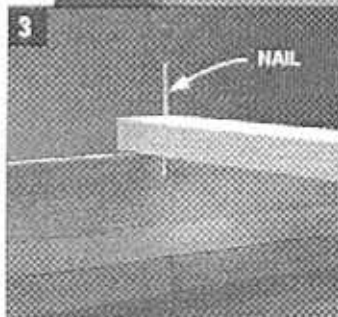
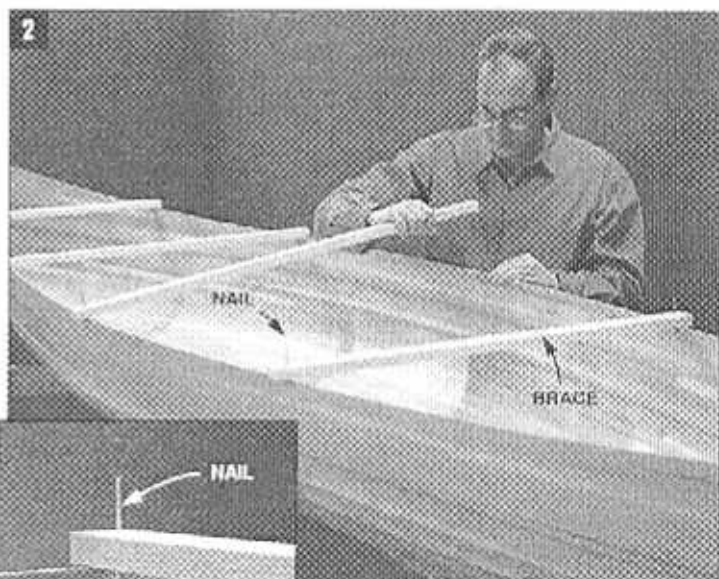

WOOD BRACES with nails at the ends keep the hull from bowing in when you're not working on it. Use the molds to determine the nail spacing.



SAND THE INSIDE using an orbital sander. Place carpet pad between the sander's pad and the sandpaper so it conforms to the canoe's shape.

FIBERGLASS THE INSIDE with overlapping pieces, starting at the center and working out. Clothespins hold the fabric in place as you apply the resin.

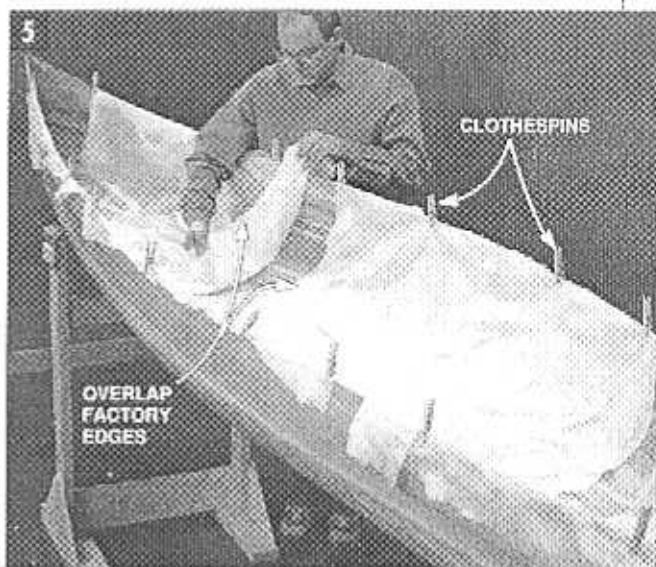

the ends, forcing them toward the middle of the canoe.

Make a set of braces, one for every other mold position, to maintain the canoe's shape while you're not working on it (Photo 2). They can be made of scrap wood strips, with nails through the ends so the distance between the nails is equal to the width of the appropriate mold. Set the braces across the canoe so the nails are inside the hull, preventing it from bowing in.

SAND THE HULL INTERIOR

Grind or file the blade of a paint scraper to match the tightest curve of the hull interior; then scrape away the dried glue and any high spots from the hull.

Sand the inside of the hull smooth (Photo 4), starting with 40-grit and going through 60-, 80- and 100-grit. Sand the narrow ends by hand. A thin stick with sandpaper wrapped around it will help you sand deep into the ends.

Apply one coat of polyurethane sanding sealer to the hull interior and sand lightly with 120-grit sandpaper after it's dry.

CUT FIBERGLASS FOR THE HULL INTERIOR

Cut the fiberglass pieces DD-FF to the dimensions given in the Cutting List. Make sure the two overlapping edges are both factory-finished edges.

Lay the fiberglass pieces DD and EE in position in the canoe and secure them with clothespins (Photo 5). Cut the inside end pieces FF to their finished shape, using the outside of the hull as a guide to the shape. Allow enough material for 1-in. overlaps at the seams. Save the scrap pieces for use as repair patches (I know, it's unthinkable, but even so...).

APPLY THE RESIN TO THE FIBERGLASS

Mix pint batches of resin so you have enough time to apply it before it sets up. Apply the resin with a paint roller. Follow the safety precautions we described in Part 2—wear gloves, goggles and a carbon-filter respirator, and have plenty of cross ventilation.

Start with the center piece DD. Roll the resin onto the fiberglass in the bottom of the boat first; work up the

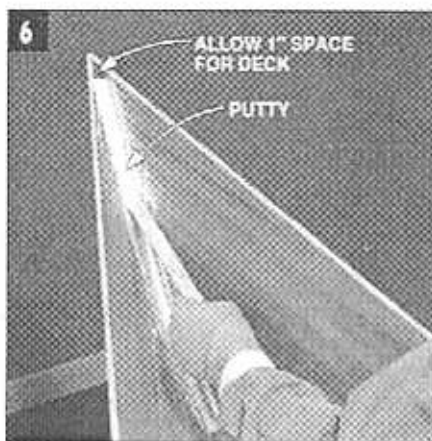

FILL THE ENDS with polyester resin putty, using a rounded-end stick to smooth it. Putty strengthens the ends and makes them easier to clean.

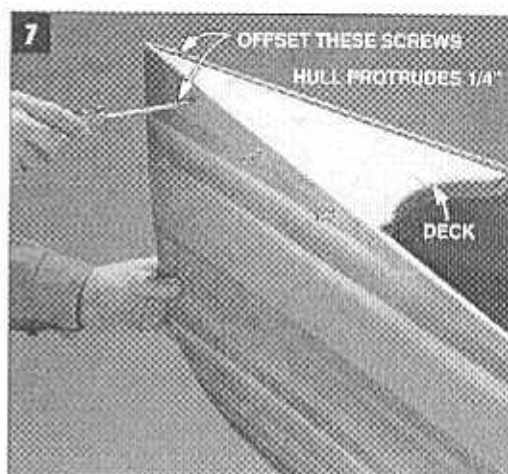

ATTACH THE ASH DECKS to the hull with stainless steel screws. Offset the two screws nearest the ends so they don't interfere with each other.

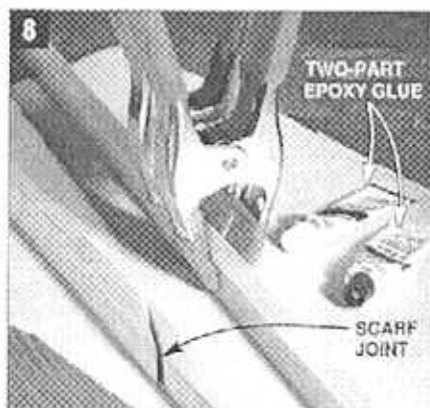

JOIN STRIPS of ash for the inwales and outwales with a "scarf joint," a low-angled lap joint. Glue the joint with epoxy.



CLAMP THE ASH INWALE to the hull 1/4 in. below the edge, and trim one end to fit. Screw the inwale to the hull, then trim the other end.

sides, removing the clothespins as you near the sheer strips; and then work out toward the ends. Apply pressure with the roller to force the fiberglass onto the hull. Make sure there are no areas where the fiberglass has pulled away from the hull. You may need to slide the fiberglass down to remove any air pockets.

Realign the adjacent fiberglass pieces EE, lap their edges 1 in. over DD, then roll on the resin.

Align and apply resin to *one* end piece FF at each end of the canoe. The other end pieces will be applied later. Use a brush to apply the resin where the roller can't reach.

Now apply a second coat of catalyzed

resin to all the fiberglass on the hull interior. Set the wood braces in place across the hull while the resin cures.

Allow the resin to cure for about one hour, then, using a utility knife, carefully cut the overhanging fiberglass edges flush with the sheer strips. Allow the resin to cure overnight with the braces in place.

Complete the inside fiberglassing by applying the final two end pieces FF. Allow this resin to cure overnight, too.

FINISH THE INSIDE ENDS

Polyester resin putty is used to seal and finish the inside ends and protect them from water damage. You mix the putty from the same resin you used for

fiberglassing, plus a silica thickener and glass micro bubbles (see Shopping List, Part 2, June '91). The thickener keeps the resin from running, and the glass micro bubbles make it stronger.

Measure the putty components by volume: Thoroughly mix one cup (8 oz.) of the glass micro bubbles into one cup (8 oz.) of resin. Add 5 oz. of the silica thickener to the resin and micro bubbles and mix together thoroughly. Complete the mixture by adding 1 teaspoon of catalyst and stir for one minute. Apply the putty in the ends with a rounded stick (Photo 6), and let it cure overnight. Be sure to avoid putting putty in the top 1 in. of the end, where the deck will fit.

Lightly sand the interior fiberglass with 120-grit sandpaper, then apply two coats of clear exterior polyurethane.

INSTALL THE DECKS

Cut the decks (GG) to size, finish sand them, and round over the back edges. Screw each deck to the hull with stainless steel screws (Photo 7). Offset the two screws at the end of each deck so they don't interfere with each other. The deck is attached so that 1/4 in. of the hull protrudes above it — this excess will be sanded off later.

ATTACH THE GUNWALES

Cut out the inwales (QQ) and outwales (VV), which together will form the gunwales of the canoe. To get pieces long enough, you may need to "scarf joint" the ends of two shorter pieces (Photo 8). Use epoxy glue.

Align and glue together the inwale pieces QQ - UU to make the inwales. Glue the blocks (TT, UU) to QQ with epoxy glue and clamp them with spring clamps. Allow the glue to cure overnight, then sand. Round over the inside edges of the inwales and the outside edges of the outwales.

The inwales and outwales are screwed, not glued, to the hull and set 1/4 in. below the top edge of the sheer strip. That's so they hide the messy area where the tapered ends of horizontal strips butt up against the sheer strip. The 1/4 in. of sheer strip that protrudes will be sanded down flush with the gunwales later (Photo 12).

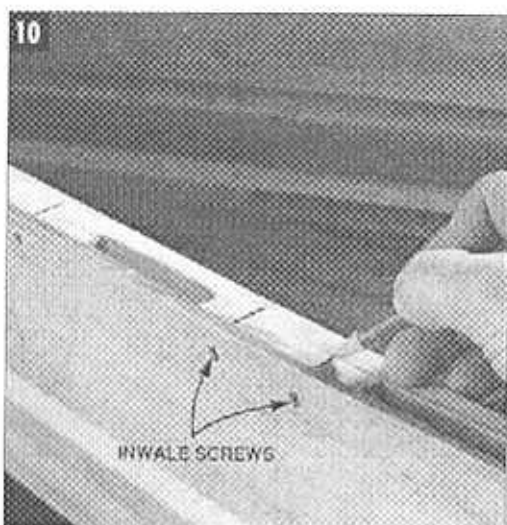

MARK THE LOCATION of the screws that hold the inwales and decks to the hull so you can screw the outwales on without screws hitting each other.

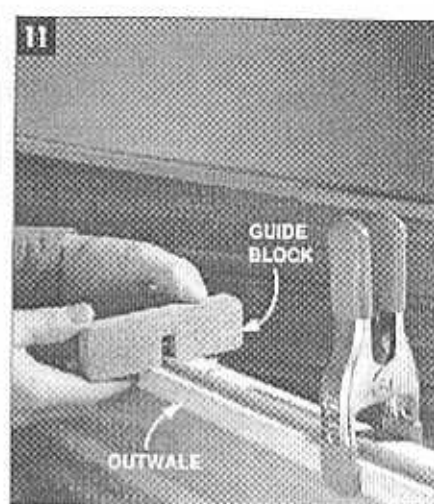

CLAMP ON THE OUTWALE and get it aligned, then screw it on. A notched block of wood helps get the outwale and inwale lined up evenly.

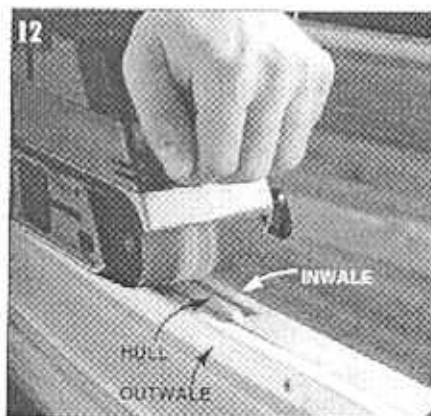

SAND THE GUNWALES FLUSH with a belt sander, removing the 1/4 in. of hull that protrudes. Hold the sander as flat as possible while you sand.

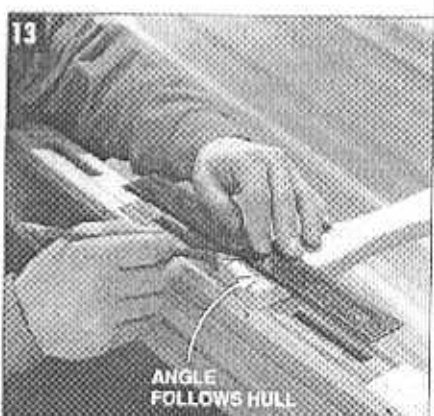

MARK THE THWARTS so they fit the angle of the hull, cut them, then bolt them underneath the inwales with stainless steel bolts.

Align and clamp one inwale to the hull. Trim one end so it fits tightly against the edge of the deck (Photo 9). Screw the inwale to the hull starting at the trimmed end and working down to the untrimmed end. Countersink the screw holes in the hull and drill pilot holes into the inwale to avoid splitting. As you near the other end, trim the inwale to fit against the deck, and finish screwing it to the hull. Repeat this procedure for the other inwale.

Mark the locations of the screws that attach the inwales and decks to the hull (Photo 10). Screw the outwales to the hull (Photo 11) just as you did for the inwales. Sand the hull flush with the

decks and gunwales (Photo 12).

MOUNT THE THWARTS

Cut the thwarts (KK) and yoke (HH) to the dimensions given in the Cutting List, shape them according to the plans, and sand the edges smooth.

Temporarily clamp the yoke under the inwales in the center of the canoe to hold the canoe at its finished width. Don't bolt it on yet. Set the thwarts on top of the gunwales, centered on their inwale mounting blocks. Mark and cut them to length (Photo 13). Clamp the thwarts under the inwales, countersink and drill their bolt holes, then bolt them in place.

ATTACH THE SEATS

Cut the seat stiles (LL) and seat rails (MM) to the Cutting List dimensions, then assemble them with dowels and epoxy glue to make the seat frame (Fig. B). The prewoven cane seat is attached as follows: (1) Rout a 1/4 x 1/4-in. groove in the tops of the seat frame, using a straightedge to guide the router when cutting the rails (Photo 14); (2) lay the woven cane sheet on top of the seat; and (3) wedge the seat material tightly down in the groove with a thin wooden strip ("splint"). Detailed instructions are supplied with the prewoven cane seat.

The seat stiles must be slightly shorter than the hull width at the gunwales. This is necessary because the seats hang down and the hull narrows as you go down. Start by cutting the seat stiles to length at the gunwales, just like the thwarts. Slowly trim the stile lengths, equally on both sides, until the seats fit where they hang without being forced against the hull. Use the seat

CUTTING LIST

KEY	PCS.	SIZE & DESCRIPTION
X	4	1-1/2" x 3-1/2" x 38" pine (sling stand legs)
Y	4	1-1/2" x 3-1/2" x 24" pine (sling stand feet)
Z	2	1-1/2" x 3-1/2" x 21" pine (sling stand braces)
AA	2	1/2" x 6" x 24" fir plywood (sling stand braces)
BB	4	1/2" x 10" x 20" fir plywood (sling stand leg supports)
CC	4	1/2" x 2" x 3-1/2" fir plywood (sling stand carpet cleats)
DD	1	52" x 60" fiberglass (inside center)
EE	2	48" x 60" fiberglass (inside ends)
FF	4	20" x 30" fiberglass (inside ends)
GG	2	3/4" x 7" x 16" ash (decks)
HH	1	3/4" x 5-1/2" x 34" ash (yoke)
IJ	2	3/4" x 4" x 3" ash (yoke pads)
KK	2	3/4" x 2-1/2" x 30" ash (thwarts)
LL	4	3/4" x 1-1/2" x 26" ash (seat stiles)
MM	4	3/4" x 1-1/2" x 8" ash (seat rails)
NN	6	3/4" x 3/4" x 2-7/8" ash (seat supports)
PP	2	3/4" x 3/4" x 2" ash (seat supports)
QQ	2	1/2" x 3/4" x 130" ash (inwales)
RR	2	1/2" x 3/4" x 40-1/2" ash (bow inwales)
SS	2	1/2" x 3/4" x 29-1/2" ash (stern inwales)
TT	6	1/2" x 3/4" x 6" ash (inwale blocks)
UU	22	1/2" x 3/4" x 4" ash (inwale blocks)
VV	2	1/2" x 3/4" x 240" ash (outwales)

Save on cable rental fees!

CABLE TV DESCRAMBLERS WE'LL BEAT ANY PRICE!

CALL TOLL-FREE 1-800
284-8432

JERROLD-TOCOM-ZENITH-HAMLIN
OAK-PIONEER-SCIENTIFIC ATLANTIC

- 24 HOUR SHIPMENTS! • QUANTITY DISCOUNTS!
- MONEY BACK GUARANTEE!
- FREE CATALOG & INFORMATION

MASTER CARD/AMEX/VISA/C.O.D.

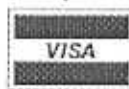

Have make and model number of
equipment used in your area ready

1-800-284-8432

FOR ORDERS ONLY

FOR TECHNICAL & CUSTOMER SERVICE

305-749-3038

CABLE WAREHOUSE

10117 WEST OAKLAND PARK BLVD. SUITE 515,
SUNRISE, FL. 33351

NO FLORIDA SALES

supports (NN, PP) as guides. For comfort, be sure the front edge of each seat is hung lower than the back.

When the seat fits, clamp it to the

FIG. B SEAT DETAIL

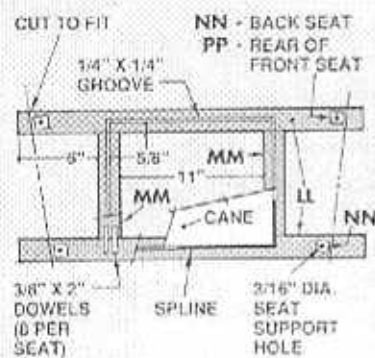

gunwale on one side, and drill the mounting holes through the seat and inwale. Drill the bolt holes at an angle to match the angle of the hull. Repeat on the other side. Drill the bolt holes through the seat supports, then bolt the seat in place (Photo 15).

APPLY THE FINISH AND MOUNT THE YOKE

Unbolt the seats and thwart and remove the yoke so they can be varnished separately. Apply two coats of polyurethane to all the trim and to the outside of the hull (Photo 16), then remount the seats and thwarts. Be sure to varnish under the decks.

If you want to put portaging pads on the yoke (Fig. C), drill holes for the bolts that join the yoke and yoke pads (HH and JJ). Hammer the T-nuts into the yoke pads, upholster them and then

FIG. C YOKE DETAIL

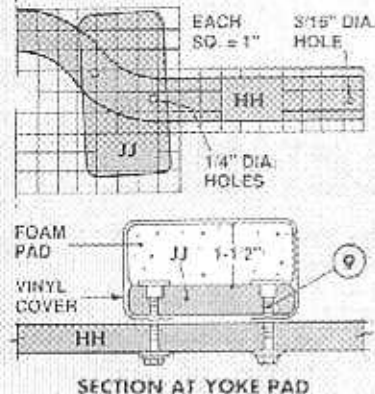

bolt them to the yoke.

Clamp the yoke to the undersides of the inwales with two small C-clamps. Set the canoe on your shoulders and see how it balances. Adjust the yoke forward or backward on the inwale until the canoe balances perfectly, then drill the yoke bolt holes and bolt it in place.

That's it — you're done! What a job,



BUILD THE SEATS from ash frames with grooves routed in them to hold the prewoven cane. A wood strip, called a "spline," is jammed in the groove to hold the cane tightly.

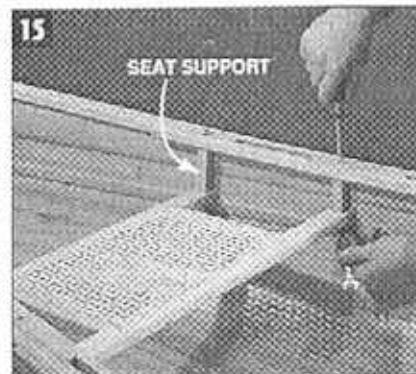

HANG THE SEATS from the gunwales with long bolts and seat support blocks. The front edge of each seat is hung lower for paddling comfort.



APPLY TWO COATS of clear exterior polyurethane to the hull and to all the ash trim. Then break out the paddles — you're finished!

and what a beautiful canoe. Here are a few tips on keeping it that way.

MAINTENANCE

To avoid cracking the hull, always load and unload the canoe while it's in the water. When the polyurethane starts to peel, clean it thoroughly, wash it with mineral spirits, and sand with 120-grit sandpaper. Apply another coat of polyurethane. If the hull becomes damaged, let it dry; sand the damaged area; put a layer of fiberglass cloth over it, then three coats of resin, just as you did when building the canoe. After the first two coats of resin are dry, sand the edges of the patch out to a leather edge. Then apply the third coat of resin and varnish. **TFH**

SHOPPING LIST: PART 3

ITEM	QUANTITY
#20 - 1/4" x 1-1/2" hex head bolts with lock and flat washers	4
#20 - 1/4" T-nuts #26054*	4
Two-part epoxy glue	1 set
#6 - 1-1/2" flat head stainless steel screws	50
#6 - 1" flat head stainless steel screws	84
#6 - 5/8" flat head stainless steel screws	24
#10 - 24 x 5" flat head bolts with nuts, lock and flat washers	2
#10 - 24 x 4" flat head bolts with nuts, lock and flat washers	8
#10 - 24 x 2" flat head stainless steel bolts with nuts, lock and flat washers	6
3/8" x 2" dowel pins	16
12" x 36" conventional weave cane #41012†	1 piece
1/4" x 10" cane spline #11100†	1 piece
1-1/2" x 4" x 5" high-density foam rubber	2
10" x 14" vinyl upholstery fabric	2
Stain exterior polyurethane	2 quarts

*Available from The Woodworkers' Store, Dept. TFH, 21801 Industrial Blvd., Rogers, MN 55374; (612) 426-2199

If you need copies of Parts 1 and 2 of this project, send for our May and June '81 issues. Write to Handyman Back Issues Dept., P.O. Box 1917, Manassas, OH 43065. The cost is \$3.60 each. A set of full-size templates is also available to help you build the molds. Write to Canoe Templates, The Family Handyman, 7900 International Drive, Suite 950, Minneapolis, MN 55425. The cost is \$10.

Editor • KEN COLLIER
 Art Direction • MIKE SMITH, GORDY WILKINSON
 How-to Photos • BILL ZUSHIKE
 Lead Photo • MIKE KRIVIT
 Technical Art • EUGENE THOMPSON
 Consultant • BOB BROWN